

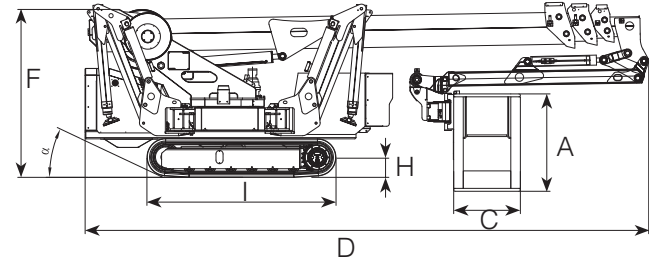

PERFORMANCE	
WORKING HEIGHT	26.20 m
HORIZONTAL OUTREACH (120 KG.)	13.50 m
UP AND OVER CLEARANCE	-
CAGE CAPACITY	230 Kg
MOVABLE JIB	180°
CAGE ROTATION	180°
TURRET ROTATION	360°
GRADEABILITY	30%
SLOPE ANGLE ( $\alpha$ )	25°
TRAVEL SPEED	1.0-2.0 Km/h

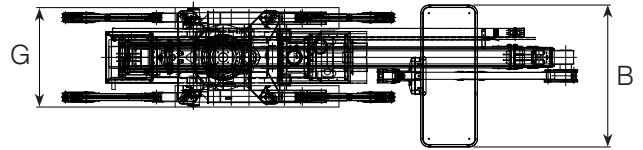

MEASURES	
CAGE HEIGHT (A)	1.10 m
CAGE LENGTH (B)	2.00 m
CAGE WIDTH (C)	0.80 m
LENGTH (D)	6.75 m
LENGTH WITHOUT CAGE (E)	-
HEIGHT (TRAVELLING POSITION) (F)	2.00 m
WIDTH, MIN (G)	1.40 m
WIDTH, MAX (G')	-
GROUND CLEARANCE (H)	0.23 m
GROUND CLEARANCE MAX (H')	-
TRACK (L x W) (I)	2.27 x 0.30 m
LENGTH OUTRIGGER STANDARD (J)	3.75 m
WIDTH OUTRIGGER STANDARD (K)	3.75 m
LENGTH OUTRIGGER NARROW (L)	4.70 m
WIDTH OUTRIGGER NARROW (M)	2.30 m
WIDTH OUTRIGGER MEDIUM (N)	3.00 m
OUTRIGGER PLATE ( $\emptyset$ )	0.20 m



WEIGHT	
TOTAL WEIGHT	5400 Kg
TRAVEL CONFIGURATION PRESSURE	2.55 kN/m <sup>2</sup>
WORK CONFIGURATION PRESSURE	3.31 kN/m <sup>2</sup>
MAX OUTRIGGER FORCE	23.54 kN

POWER SOURCES	
STANDARD Diesel Engine	28 kW
STANDARD Electric Motor	220V - 2.3 kW
OPTIONAL Lithium Battery	48V - 200 Ah
FUEL TANK CAPACITY Diesel Engine	30 l
OIL TANK CAPACITY	90 l

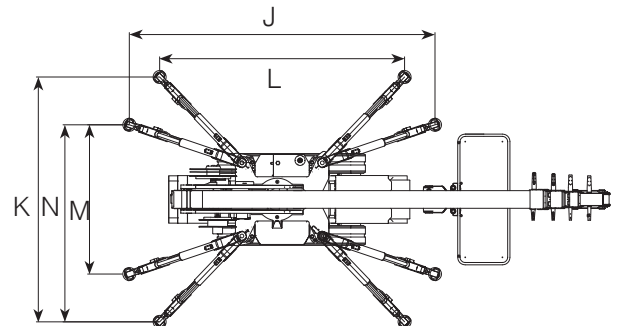

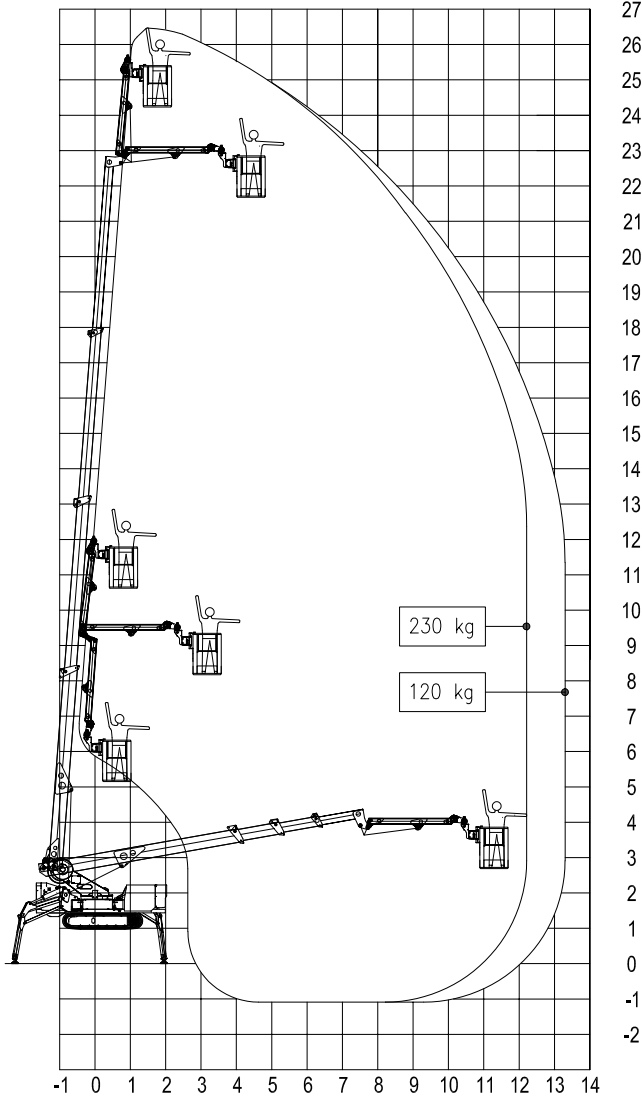

## CHASSIS

- Powerful track drive with hydraulic braking system
- Precise manoeuvring over sensitive radio control
- Rubber tracks with specially arranged profile providing optimum grip

## STABILISATION

- Variable outrigger system with one side or both sides narrow or wide setup option

## BOOM SYSTEM

- Telescopic boom + jib
- Articulated Jib 180°
- Turnable basket 180°
- Electric proportional (Danfoss) and radio controls
- Electric cage self levelling system
- Turret rotation with slewing ring

## POWER SOURCES

- 220V electric motor
- 28 kW diesel engine with electronically regulated engine control
- Start/ Stop device for the engine in the cage

## PRODUCTIVITY, SAFETY & QUALITY

- 110V (US) / 230V (EU) power socket in the cage
- High quality paint in RAL 9003 & RAL 2001
- Hand pump for emergency lowering
- Lock valves on hydraulic cylinders
- Relief valves protecting the hydraulic system from too high pressures
- Protective covers for all components
- Hour meter

## OPTIONS

- Battery drive (lithium) 48V 200 Ah (R260HY)
- Outrigger self levelling system
- Outrigger pads
- Non marking rubber tracks
- Custom paintwork
- Electric pump for emergency lowering