

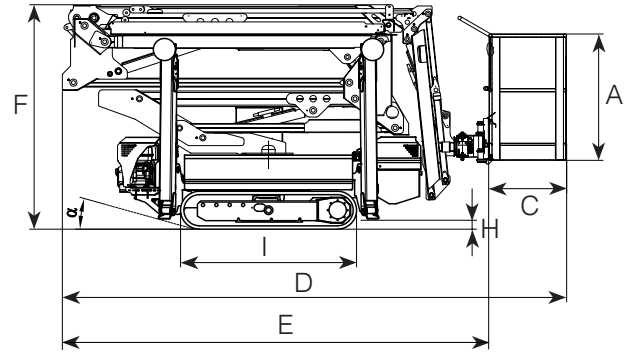

PERFORMANCE	
WORKING HEIGHT	15.00 m
HORIZONTAL OUTREACH (230 KG.)	6.80 m
UP AND OVER CLEARANCE	6.20 m
CAGE CAPACITY	230 Kg
MOVABLE JIB	90°
CAGE ROTATION	120°
TURRET ROTATION	360°
GRADEABILITY	30%
SLOPE ANGLE (α)	16° - 20°
TRAVEL SPEED	2.0 Km/h

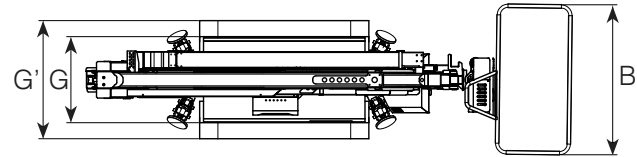

MEASURES	
CAGE HEIGHT (A)	1.10 m
CAGE LENGTH (B)	1.40 m
CAGE WIDTH (C)	0.70 m
LENGTH (D)	4.56 m
LENGTH WITHOUT CAGE (E)	3.90 m
HEIGHT (TRAVELLING POSITION) (F)	2.00 m
WIDTH, MIN (G)	0.80 m
WIDTH, MAX (G')	1.10 m
GROUND CLEARANCE, MIN (H)	0.08 m
GROUND CLEARANCE, MAX (H')	-
TRACK (L x W) (I)	1.58x 0.20 m
LENGTH OUTRIGGER STANDARD (J)	2.94 m
WIDTH OUTRIGGER STANDARD (K)	2.98 m
OUTRIGGER PLATE (\varnothing)	0.20 m



WEIGHT	
TOTAL WEIGHT	2000 Kg
TRAVEL CONFIGURATION PRESSURE	2.05 kN/m ²
WORK CONFIGURATION PRESSURE	2.50 kN/m ²
MAX OUTRIGGER FORCE	12.75 kN

POWER SOURCES	
STANDARD Petrol Engine	9.6 kW
STANDARD Electric Motor	230V - 2.2 kW
OPTIONAL Diesel Engine	7.3 kW
OPTIONAL Lithium Battery	48V - 100 Ah
FUEL TANK CAPACITY Diesel Engine	5 l
OIL TANK CAPACITY	30 l

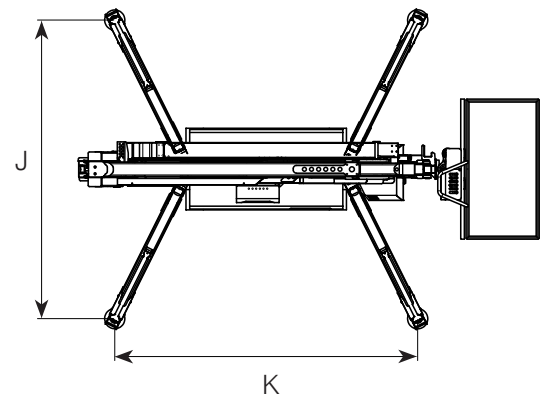

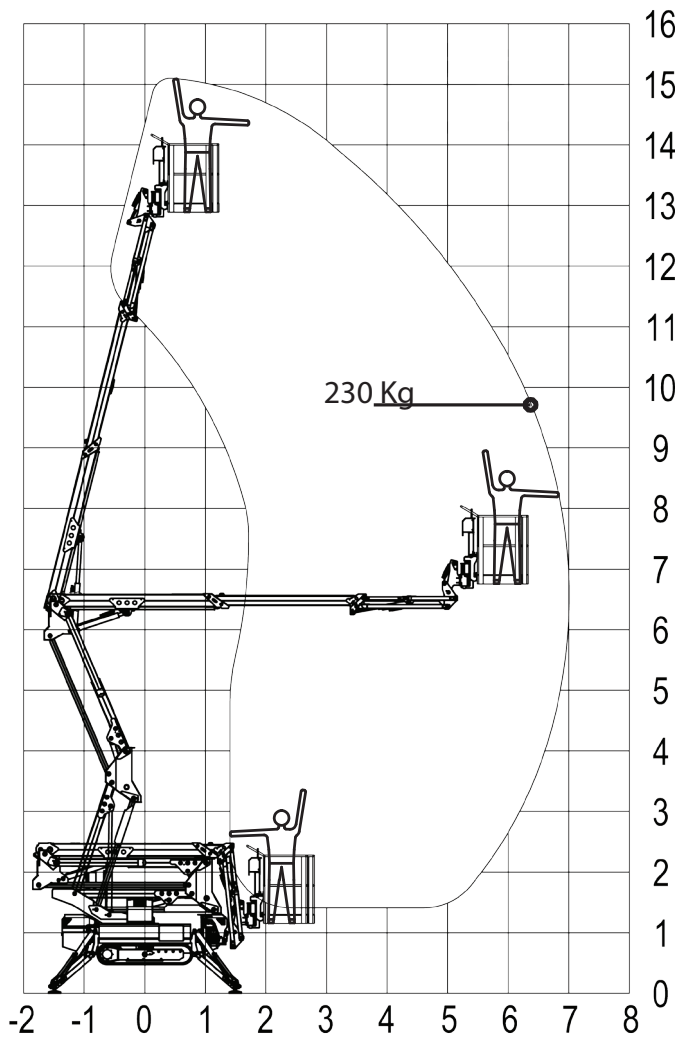

CHASSIS

- Powerful track drive with hydraulic braking system
- Precise manoeuvring over cable control
- Rubber tracks with specially arranged profile providing optimum grip

BOOM SYSTEM

- Double pantograph
- Articulated Jib 90°
- Turnable basket 120°
- Fully hydraulic controls
- Hydraulic cage self levelling system
- Turret rotation with slewing ring

OPTIONS

- Battery drive (lithium) 48V 100 Ah (RA15BA)
- Outrigger self levelling system
- Outrigger pads
- Non marking rubber tracks
- Custom paintwork
- Radio control (tracks + outriggers)
- Electric pump for emergency lowering

POWER SOURCES

- 110V (US) / 230V (EU) electric motor
- 9.6 kW Honda petrol engine
- Start/ Stop device for the engine in the cage

PRODUCTIVITY, SAFETY & QUALITY

- 110V (US) / 230V (EU) power socket in the cage
- High quality paint in RAL 9003 & RAL 2001
- Hand pump for emergency lowering
- Lock valves on hydraulic cylinders
- Relief valves protecting the hydraulic system from too high pressures
- Protective covers for all components
- Hour meter